

2.92mm

CONNECTOR SERIES

INTERFACE MATING DIMENSIONS SPECIFICATIONS

CONTENT:

- Direct Solder Plug
- Direct Solder Jack
- Plug To Plug Adaptor
- Plug To Jack Adaptor
- Jack To Jack Adaptor
- Panel Recept Plug*accepts Pin
- Panel Recept Jack*accepts Pin

Bridging Gaps



2.92mm series

The 2.92mm series was designed with highly rugged physical interfaces in mind that would mate with 3.5mm and SMA dimensions. The 2.92mm series use an air dielectric, with the performance up to 40 GHz. The outer contact ID is 2.92 mm, and OD is 4.55 mm.

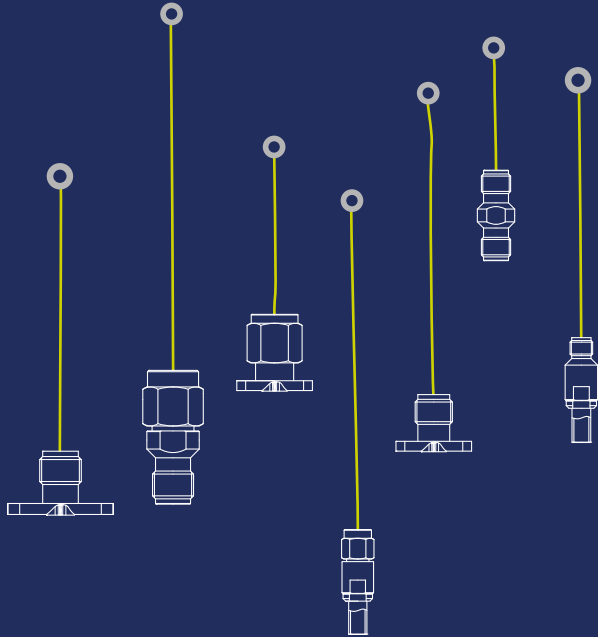

INTERFACE MATING DIMENSIONS

PLUG /

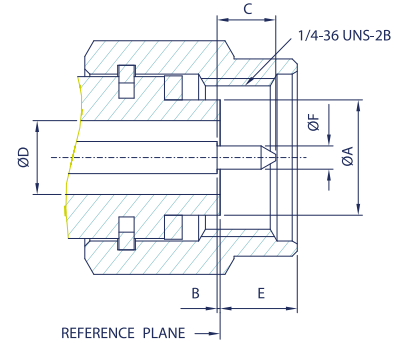

JACK /

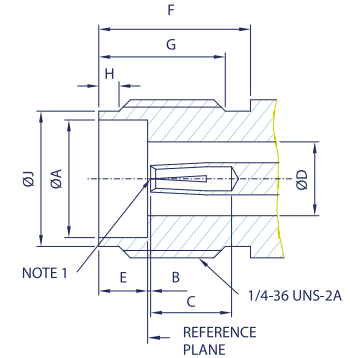

PLUG		
Letter	Millimeters	
	Minimum	Maximum
A	4.53	4.57
B	0.00	0.13
C	1.55	1.65
D	2.89	2.95
E	-	3.28
F	0.91	0.94

JACK		
Letter	Millimeters	
	Minimum	Maximum
A	4.6	4.64
B	0.00	0.13
C	2.80	-
D	2.89	2.95
E	1.88	1.98
F	5.90	-
G	4.40	-
H	0.70	0.90
J	5.30	5.40

NOTE 1: I.D. TO MEET VSWR AND CONTACT RESISTANCE WHEN MATED WITH 0.9 / 0.94 MM DIA. PIN.

SPECIFICATIONS

Electrical /

Impedance	50 Ohm	
Frequency Range	0 - 40 GHz	
Working Voltage	250 VRMS Max.	
Dielectric Withstanding Voltage	750 VRMS Min.	
VSWR	Straight	1.3 Max.
	Right Angle	1.5 Max.
Contact Resistance	Center Contact	3 Milliohms Max.
	Outer Contact	2 Milliohms Max.
Insulator Resistance	5000 Megohms Min.	

Material /

Parts Name	Material	Finish
Body, Metal Parts	Stainless Steel per QQ-764	Passivated
Center Contacts	Male: Brass per QQ-B-626	Gold 50 micro-inches
	Female: Beryllium copper per QQ-C-530	Gold 50 micro-inches
Insulators	Rexolite	None
Clamp Gaskets	Silicone rubber	None

NOTE: Other Material / Finish is Available on Request.

Mechanical & Environmental /

Engagement Force	2 in-lbs. Max.
Disengagement Force	2 in-lbs. Max.
Coupling Nut Retention	60 lbs. Min.
Coupling Proof Torque	15 in-lbs. Min.
Contact Retention	6 lbs. Min.
Durability (Mating)	500 cycles Min.
Temperature Range	-40°C to 85°C
Vibration	MIL-STD-202 Method 204 Test Cond.B.
Salt Spray	MIL-STD-202 Method 101 Test Cond.B.
Thermal Shock	MIL-STD-202 Method 107 Test Cond.B.

2.92mm series

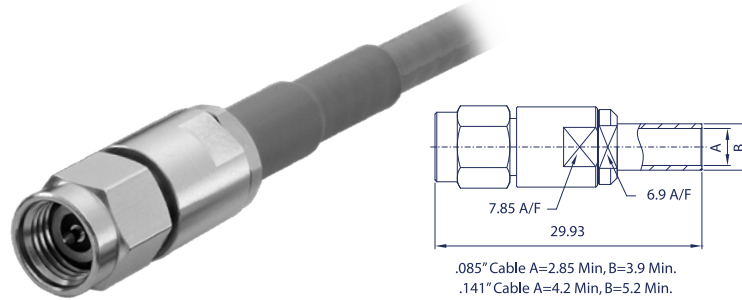

DIRECT SOLDER PLUG

Model No.	Cable Group	Impedance
FL38P2-NS5	RG-402 (.141"), SS-402 RG-405 (.085", .086"), SS-405 IW 1501 IW 1503	50

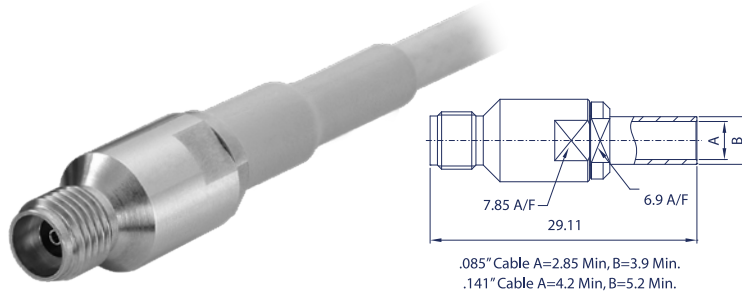

DIRECT SOLDER JACK

Model No.	Cable Group	Impedance
FL38J2-NS5	RG-402 (.141"), SS-402 RG-405 (.085", .086"), SS-405 IW 1501 IW 1503	50

04

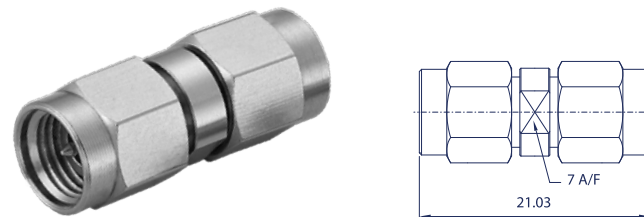
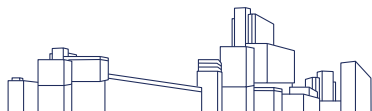

PLUG TO PLUG ADAPTOR

Model No.	Cable Group	Impedance
FL38B8-NS5	N/A	50

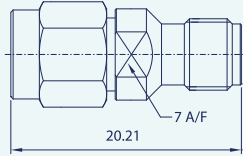
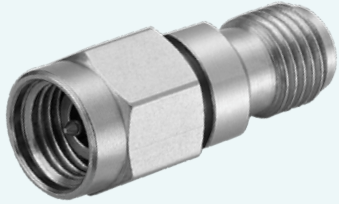

PLUG TO JACK ADAPTOR

Model No.	Cable Group	Impedance
FL38E8-NS5	N/A	50

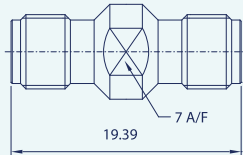

JACK TO JACK ADAPTOR

Model No.	Cable Group	Impedance
FL38G8-NS5	N/A	50

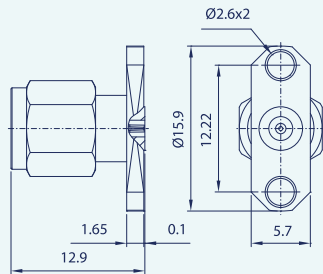
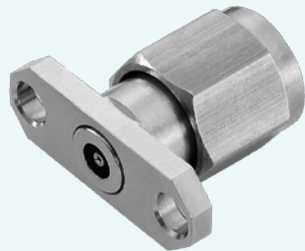

PANEL RECEIPT PLUG-ACCEPTS PIN

Model No.	Cable Group	Impedance
FL38P9-ES505	N/A	50

2.92mm series

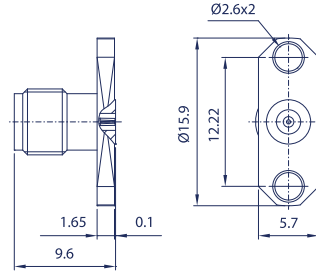

PANEL RECEIPT JACK-ACCEPTS PIN

Model No.	Cable Group	Impedance
FL38J9-ES505	N/A	50

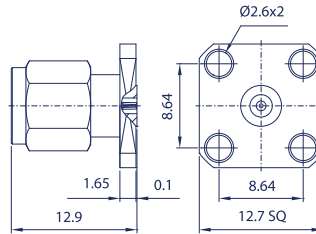

PANEL RECEIPT PLUG-ACCEPTS PIN

Model No.	Cable Group	Impedance
FL38P9-FS505	N/A	50

06

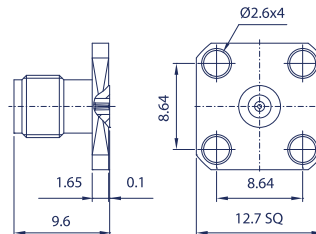

PANEL RECEIPT JACK-ACCEPTS PIN

Model No.	Cable Group	Impedance
FL38J9-FS505	N/A	50